

LOCUS MAP SCALE: 1"=2,000'±

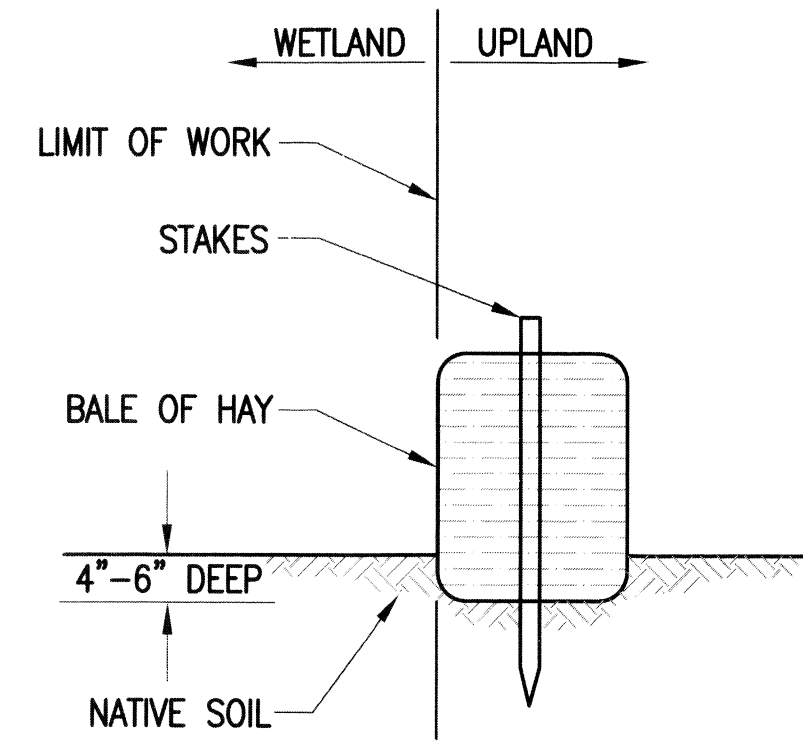

STAKED HAY BALES

NOT TO SCALE



EXISTING	LEGEND	PROPOSED
	CONTOUR LINE	
	SPOT GRADE	
	BORDERING VEGETATED WETLAND LINE AND FLAG	
	CHAIN LINK FENCE	
	SPLIT RAIL FENCE	
	HAY BALES	
	WATER LINE	
	OVERHEAD WIRES	
	UTILITY POLE	
	GUY WIRE	
	TEST HOLE	

RECORD OWNER:
 ASSESSORS MAP 12 LOT 147
 HENRY D. ROSE & MARY F. ROSE
 65 BALDWIN STREET
 EAST PROVIDENCE, RI 02914
 DEED BOOK 1679 PAGE 528

GENERAL NOTES:

- PROPERTY LINE & TOPOGRAPHIC SURVEY PERFORMED BY THOMPSON FARLAND, INC. IN FEBRUARY 2014.
- ELEVATIONS REFER TO AN ASSUMED DATUM.
- WETLANDS WERE DELINEATED ON NOVEMBER 29, 2013 BY ECOSYSTEM SOLUTIONS, INC.
- THE LOCATION OF UNDERGROUND UTILITIES WAS TAKEN FROM THE BEST AVAILABLE INFORMATION AND IS NOT WARRANTED TO BE CORRECT, NOR THAT ALL UNDERGROUND UTILITIES ARE SHOWN. IT SHALL BE THE CONTRACTOR'S RESPONSIBILITY TO NOTIFY ALL UTILITY COMPANIES AND AGENCIES PRIOR TO CONSTRUCTION FOR THE LOCATION OF UNDERGROUND UTILITIES.
- BY GRAPHIC PLOTTING ONLY, THE PROPERTY DEPICTED ON THIS PLAN FALLS IN ZONE X, AS SHOWN ON THE FLOOD INSURANCE RATE MAP, 25005C0204F DATED JULY 7, 2009.

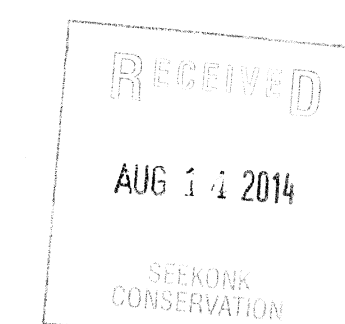
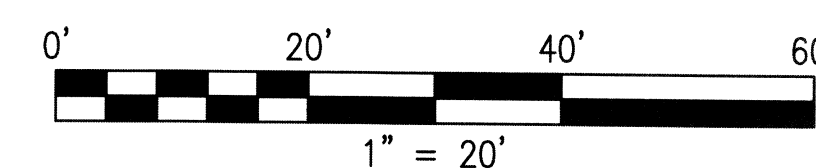
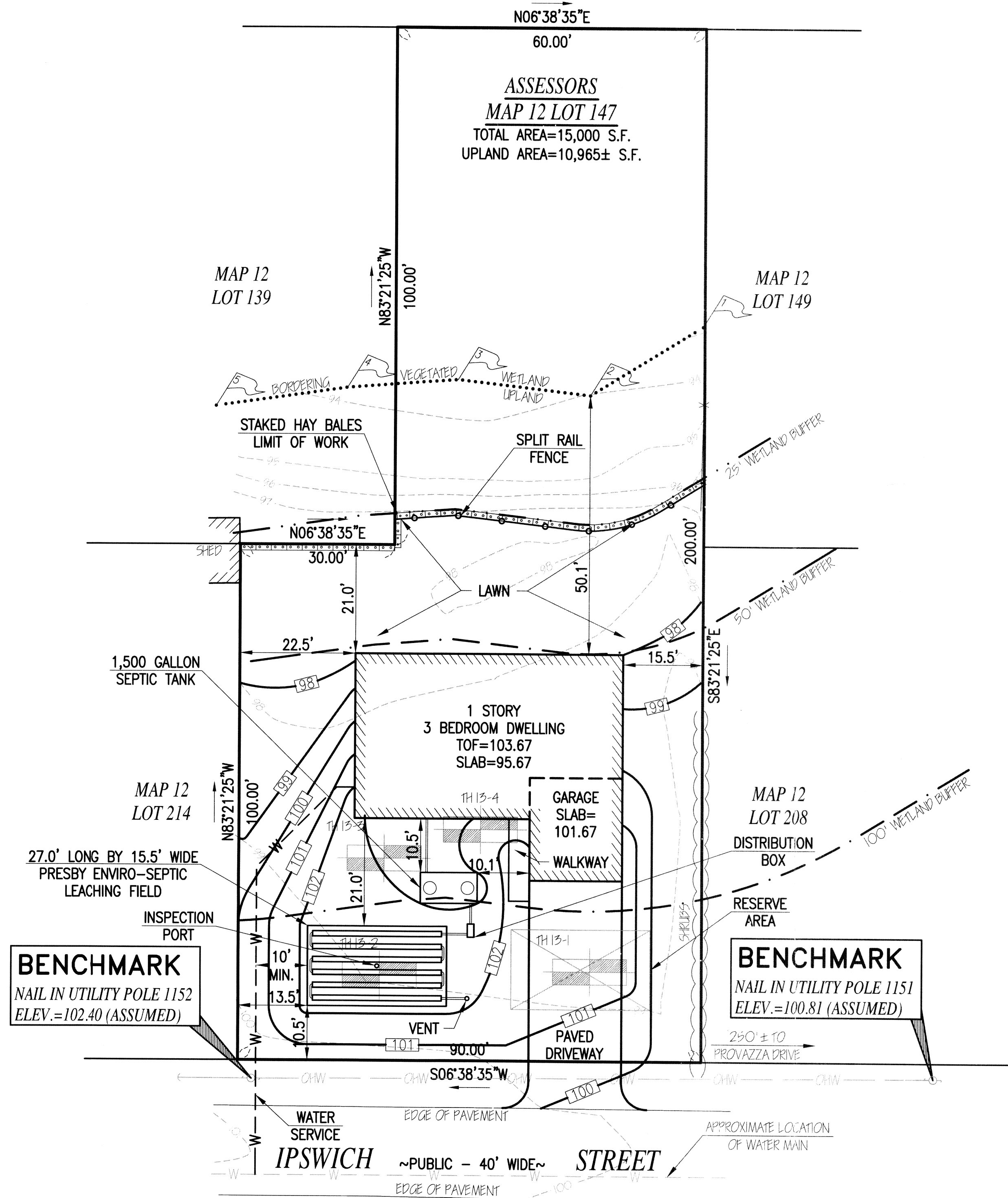

REVISIONS

1	07/11/14	PER CONSERVATION COMMENTS
2	08/13/14	DELETE FENCE

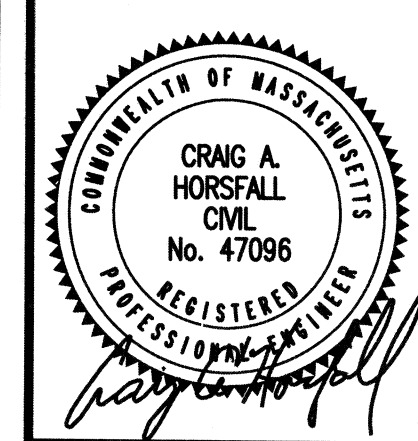

THOMPSON FARLAND
 PROFESSIONAL ENGINEERS // LAND SURVEYORS
 www.ThompsonFarland.com
 (MAIN OFFICE) 398 COUNTY STREET, NEW BEDFORD, MA 02740 P.508.717.3479
 NEW BEDFORD | TAUNTON | CAMBRIDGE | MARLBOROUGH

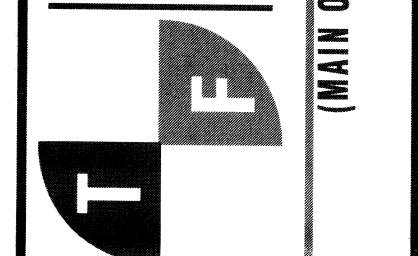

DRAWN BY: SC
 DESIGNED BY: SC
 CHECKED BY: CAH

CONSERVATION PLAN
 IPSWICH STREET
 ASSESSORS MAP 12 LOT 147
 SEEKONK, MASSACHUSETTS
 PALMER RIVER DEVELOPMENT
 PO BOX 41
 SWANSEA, MA 02771

PREPARED FOR:
 JULY 11, 2014
 SCALE: 1"=20'
 JOB NO. 13-1127
 SHEET 1 OF 1