

...OUS AREA WITHIN THE  
...FFER ZONE

... = 830 SF  
... = 775 SF  
... = 1,605 SF

... = 576 SF  
... = 255 SF  
... = 80 SF  
...LLING = 1,800 SF  
... = 2,711 SF

... = 1,605 SF = 1,106 SF  
...ONAL IMPERVIOUS AREA

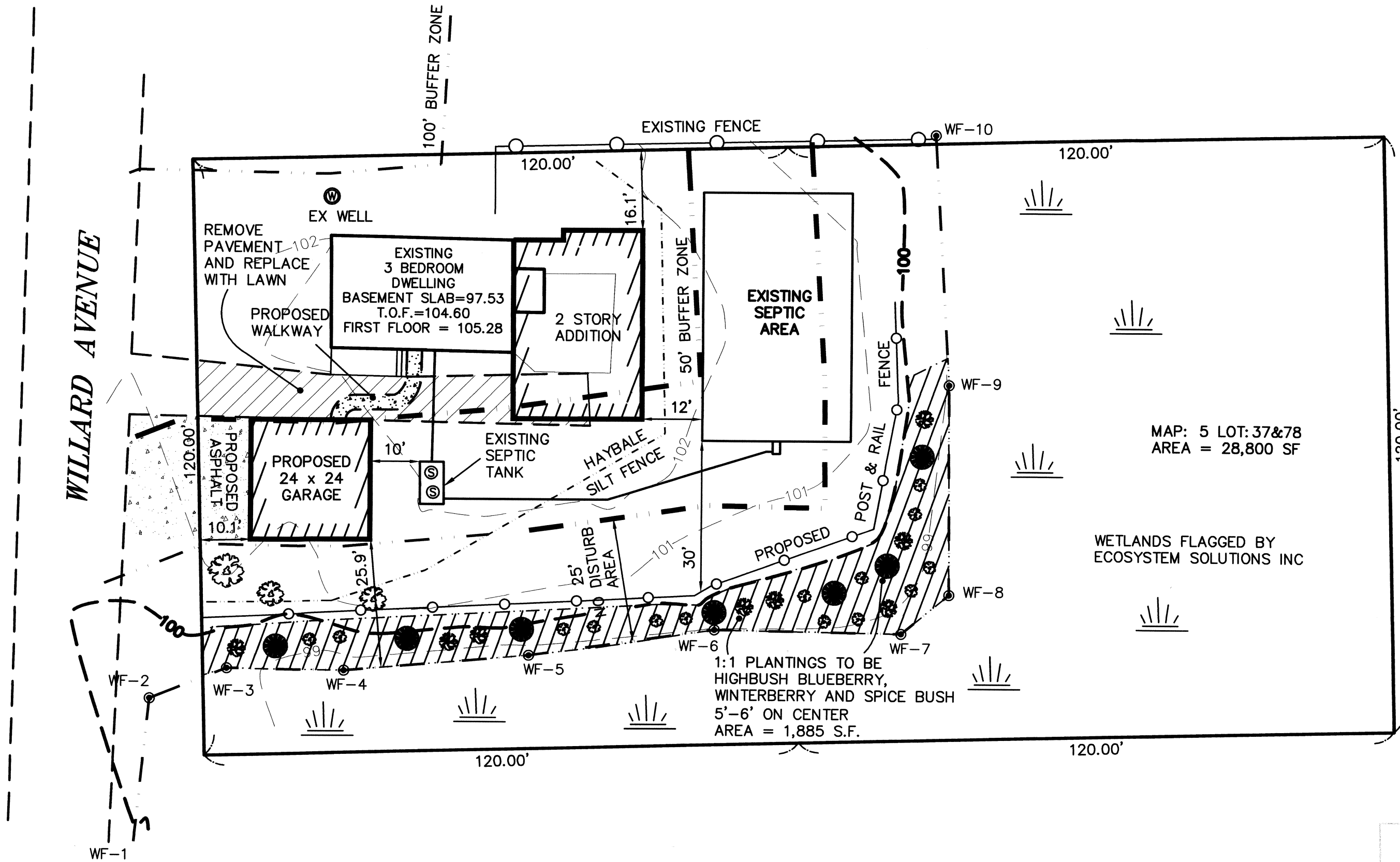

MAP: 5 LOT: 37&78  
AREA = 28,800 SF

WETLANDS FLAGGED BY  
ECOSYSTEM SOLUTIONS INC

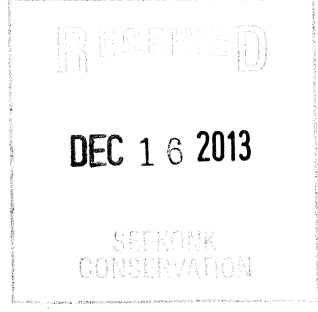

ZONING DISTRICT R-1/R-4

FRONT SETBACK = 50'  
SIDE SETBACK = 40'  
REAR SETBACK = 80'

DWELLING CREATED BEFORE R-4 DISTRICT WAS CREATED  
LOT IS NOT IN GROUNDWATER AQUIFER PROTECTION DISTRICT OR  
WETLANDS AND FLOODPLAIN PROTECTION DISTRICT

- NOTE:  
NO ADDITIONAL BEDROOMS ARE TO BE ADDED.  
BEDROOMS DELETED AND ADDED SHOULD EQUAL 3.  
A BEDROOM IS DEFINED AS A ROOM HAVING:
1. FLOOR SPACE OF NO LESS THAN 70 SQ. FT.
  2. A CEILING HEIGHT OF NO LESS THAN 7'-0"
  3. AN ELECTRICAL SERVICE AND VENTILATION.
  4. AT LEAST ONE WINDOW

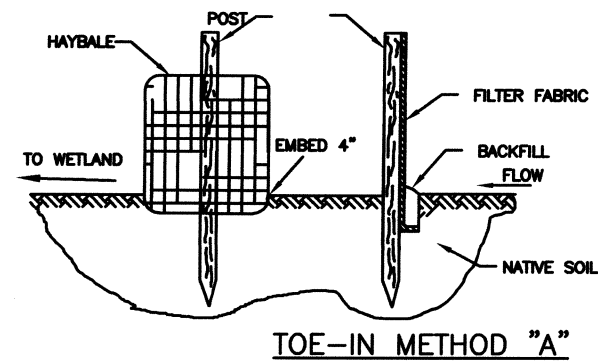

TOE-IN METHOD "A"

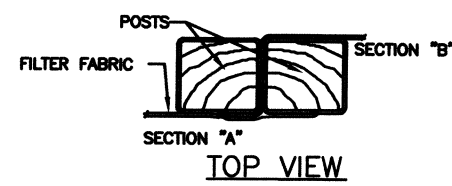

TOE-IN METHOD "B"

TOE IN METHODS

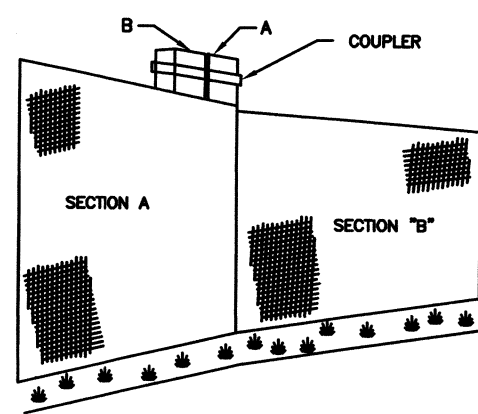

JOINING SECTIONS OF SILT FENCE

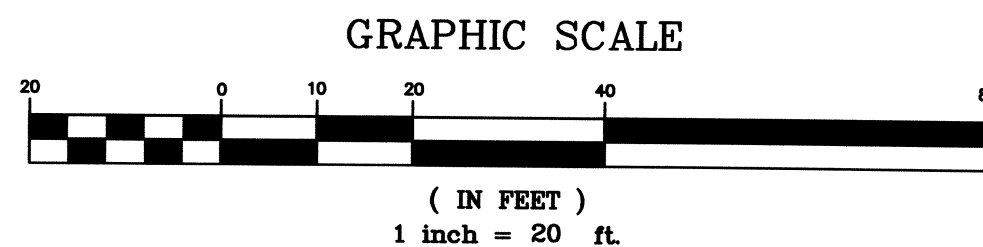

*Matthew Olsen*

**SILT FENCE/HAYBALES DETAIL**

NOT TO SCALE

SCALE: 1" = 20'  
DATE: 10/07/13  
DWG. BY: M.H.  
REVISED: 11/20/13, 12/9/13  
DWG. NO.: 13-247  
JOB NO.: 13-247

TITLE: **PLAN TO ACCOMPANY NOTICE OF INTENT**  
PROJECT: MATTHEW OLSEN  
200 WILLARD AVENUE  
SEEKONK, MASSACHUSETTS

**Mount Hope**  
ENGINEERING, Inc.  
CIVIL/ENVIRONMENTAL SERVICES  
1788 G.A.R. Highway  
Swansea, MA 02777  
ph. 508-379-1234  
fax 508-379-0727

DRAWING NO.