

- NOTES:**
1. MAXIMUM LENGTHS USING 8' & 10' RADII, WITH 90° ANGLE, ARE 4'-2" AND 5'-3" RESPECTIVELY.
  2. MINIMUM LENGTH OF STRAIGHT OR CIRCULAR FILLER PIECES TO BE 3'-0".
  3. TOP SURFACE TO BE DRESSED BY SAW.
  4. CIRCULAR CURB IS REQUIRED ON CURVES WITH RADII OF 100' OR LESS. STRAIGHT CURB TO BE USED ON CURVES OF MORE THAN 100' RADII.

**GRANITE CURB**

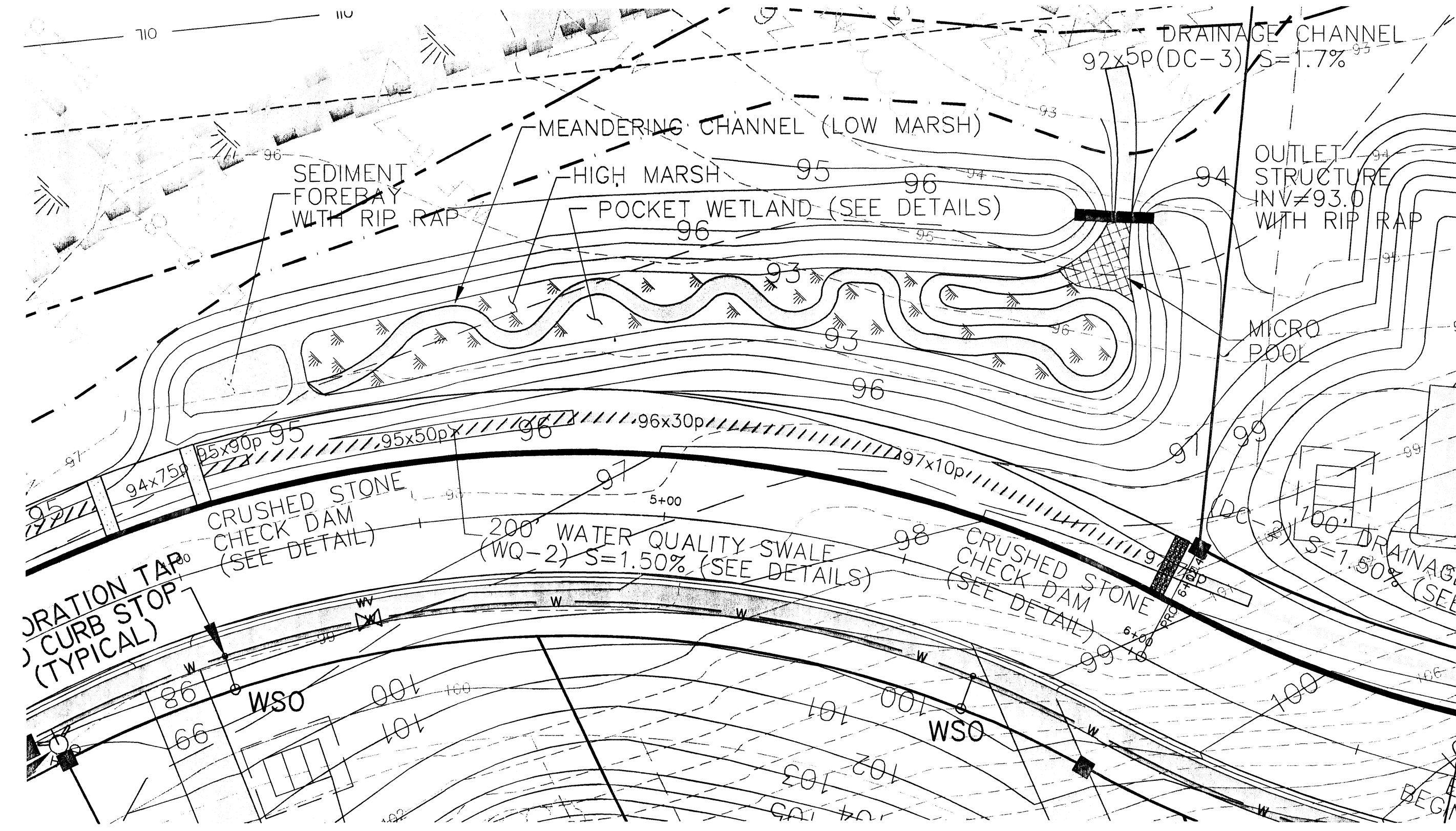

**CONSTRUCTED (POCKET) WETLAND DETAIL**

SCALE: 1" = 20'

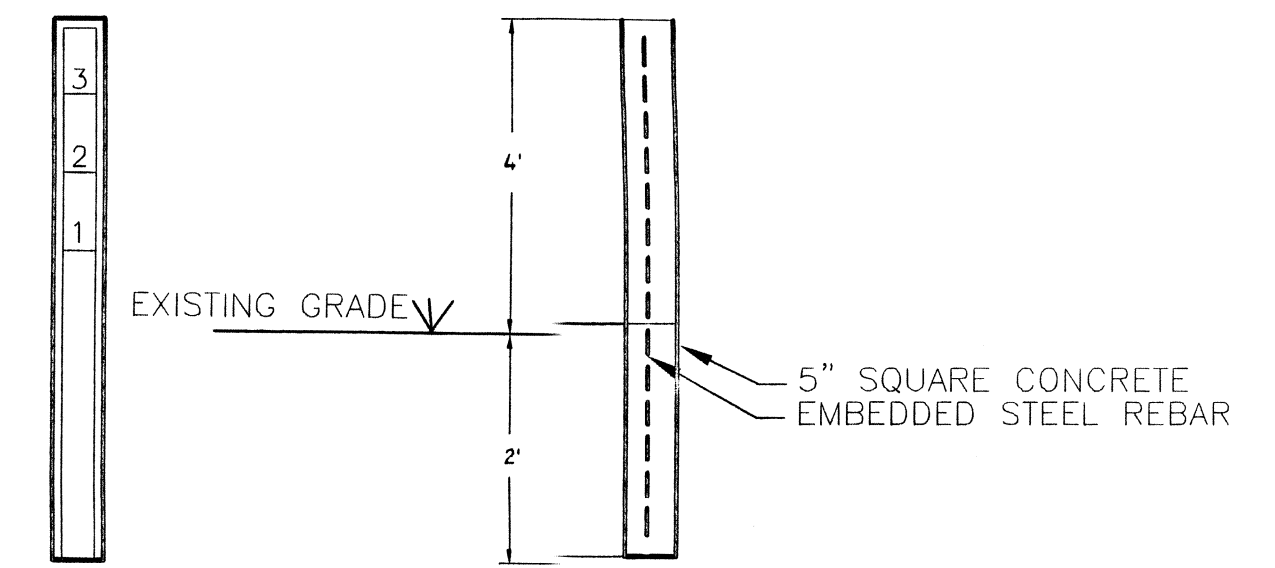

**CONCRETE SEDIMENT MARKER**

NOT TO SCALE

**SEDIMENT STORAGE**

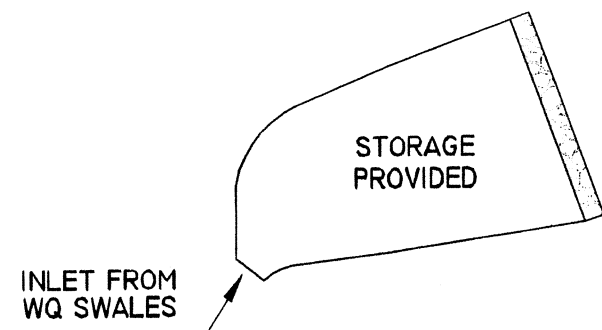

**REQUIRED VOLUME:**  
55,200 SF - 16,800 SF ROOFTOP AREA = 38,400 SF  
SEDIMENT VOLUME = 38,400 SF X 0.10 IN X 1 FT / 12 IN = 320 CF

**PROVIDED VOLUME:**  
2' X 200 SF = 400 CF  
(BELOW ELEV. 93.0)

**SEDIMENT FOREBAY**

NOT TO SCALE

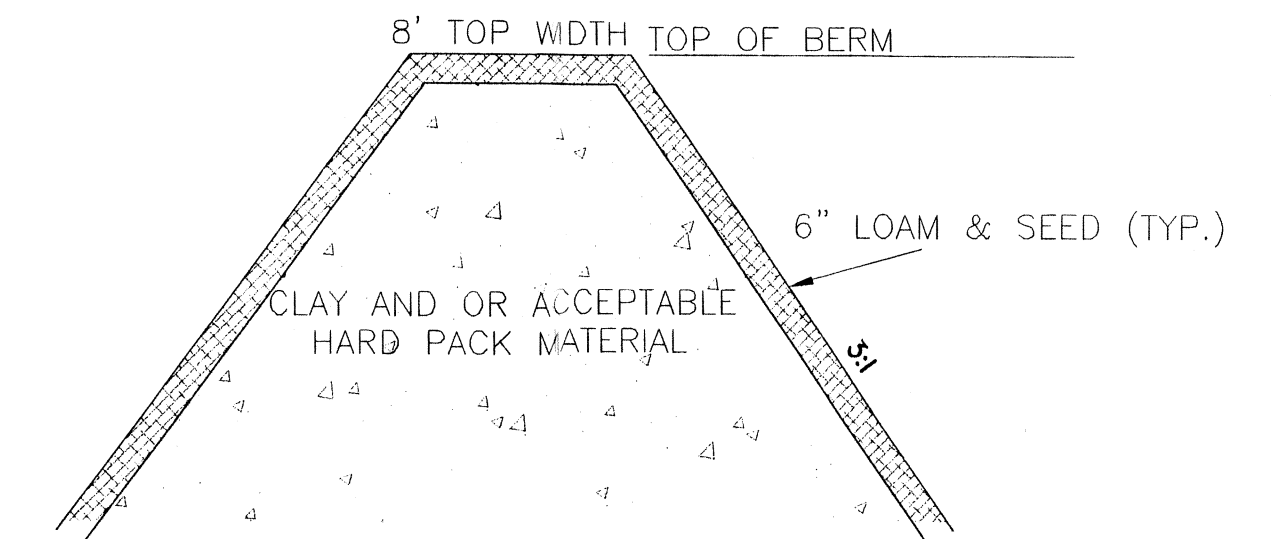

**TYPICAL DIKE SECTION DETAIL**

NOT TO SCALE

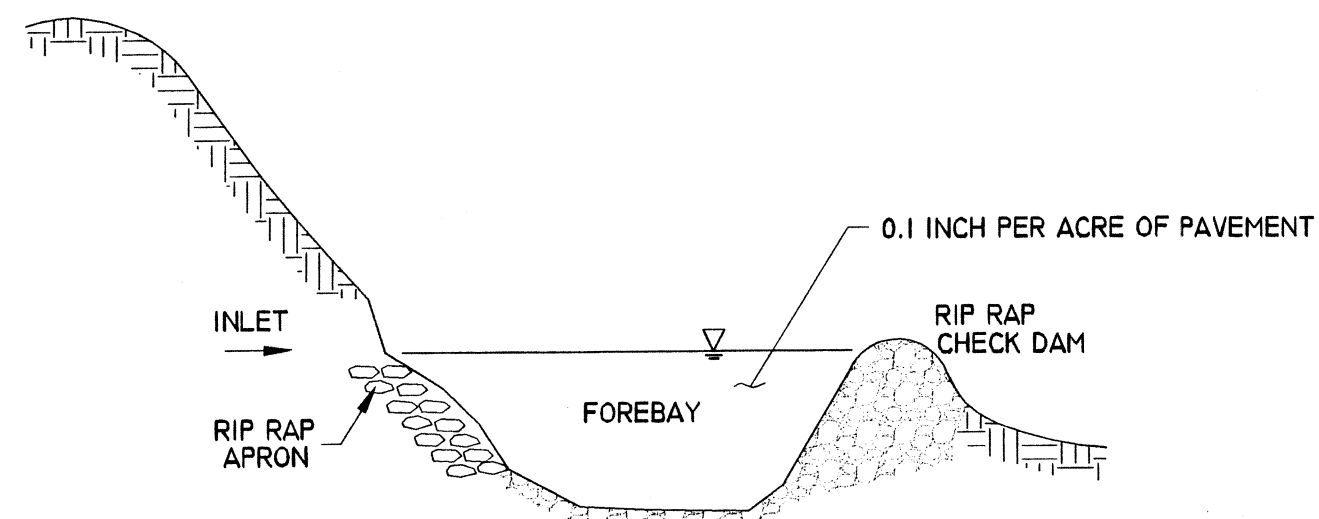

**SEDIMENT FOREBAY - SECTION**

NOT TO SCALE

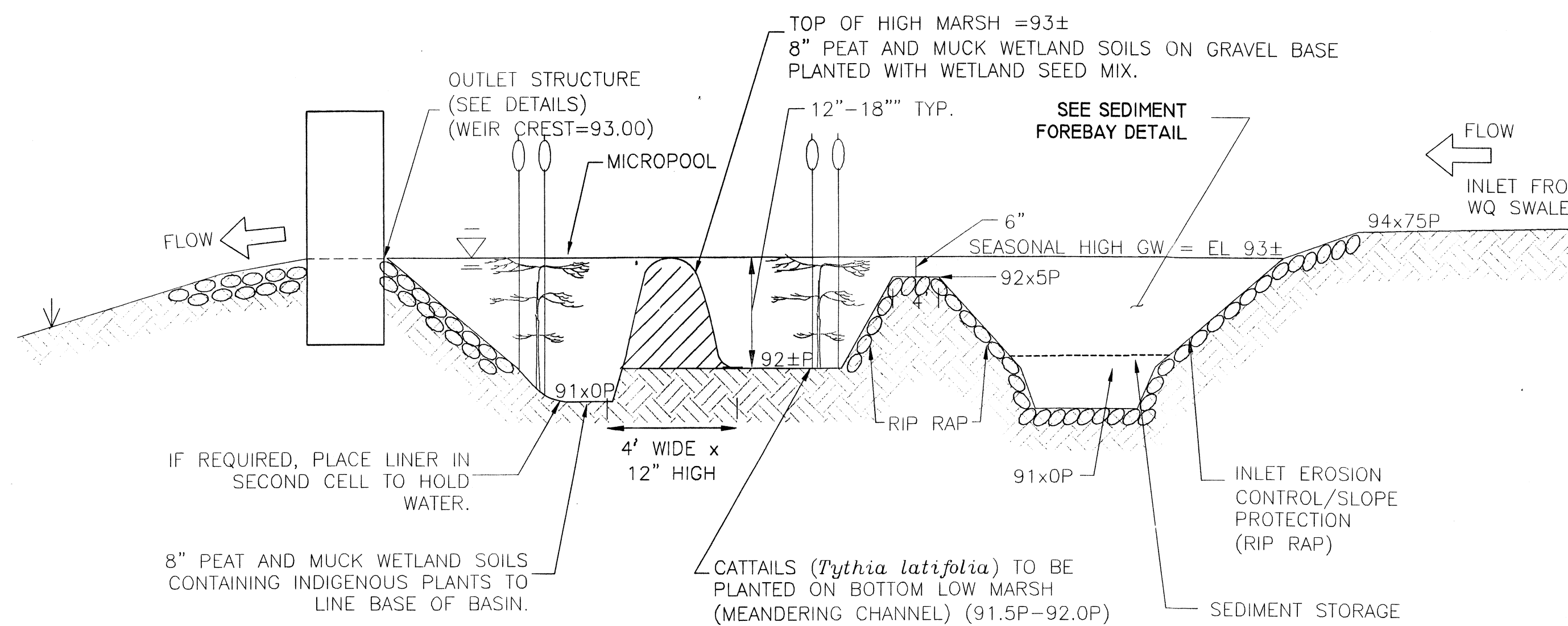

**CONSTRUCTED (POCKET) WETLAND SECTION**

NOT TO SCALE

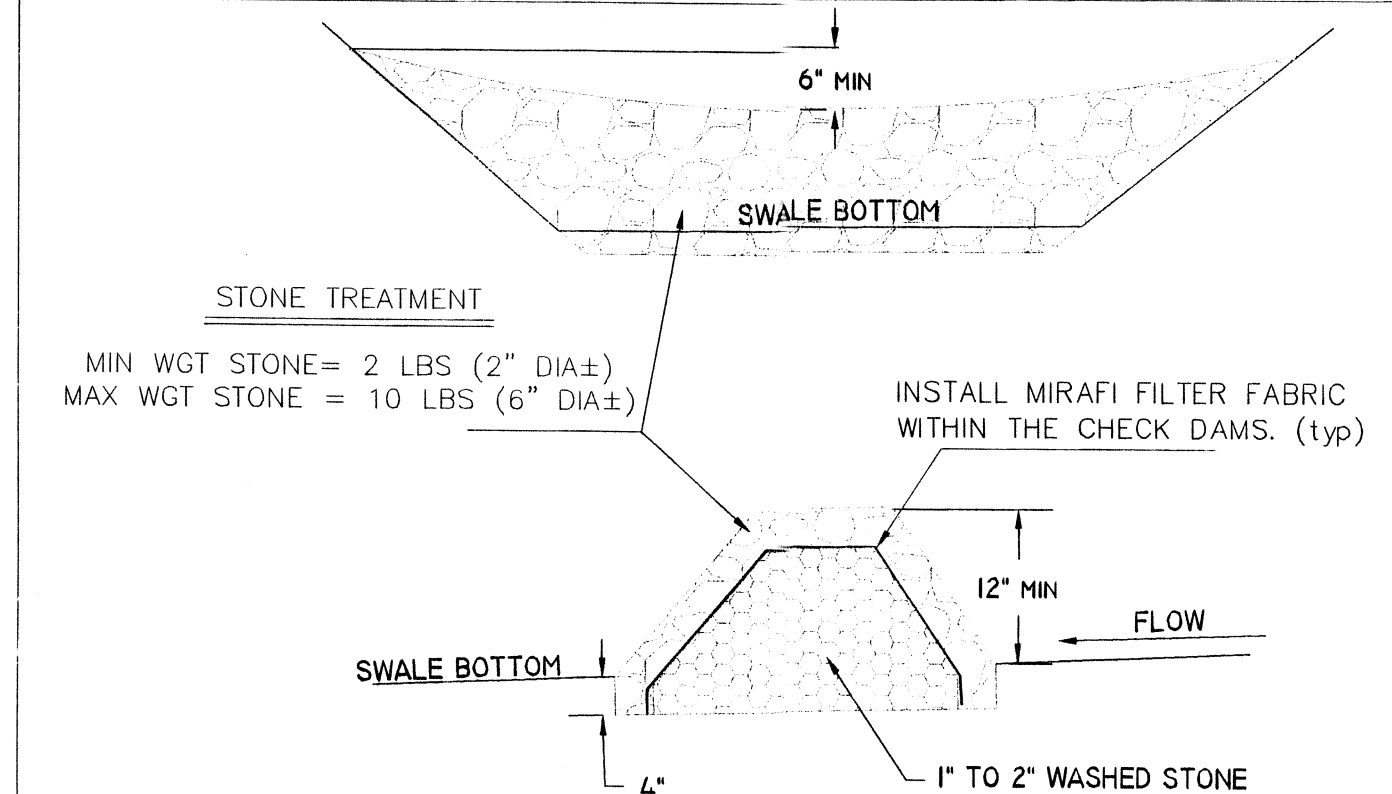

**CHECK DAM DETAIL**

NOT TO SCALE

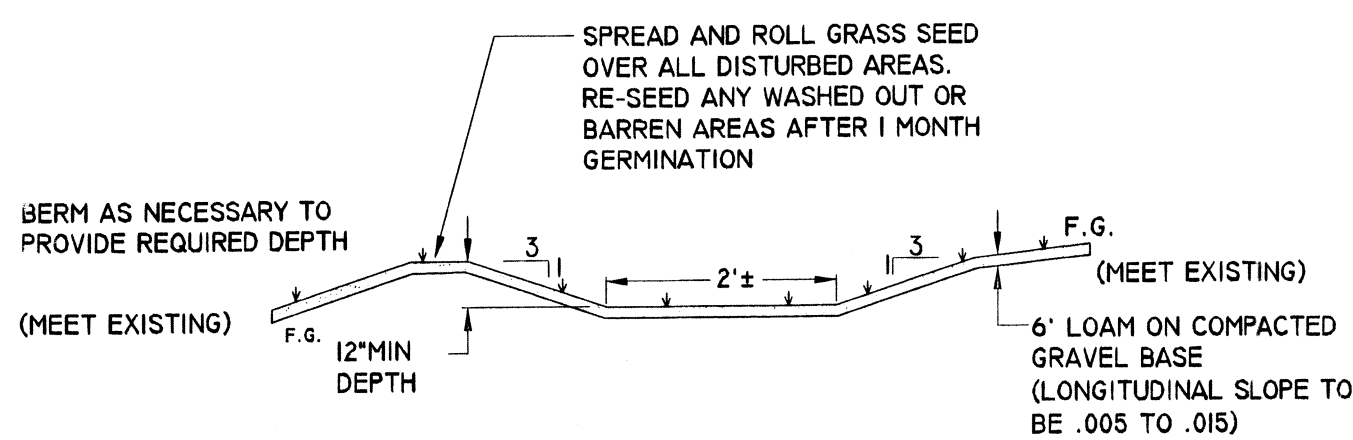

**DRAINAGE CHANNEL - SECTION**

NOT TO SCALE

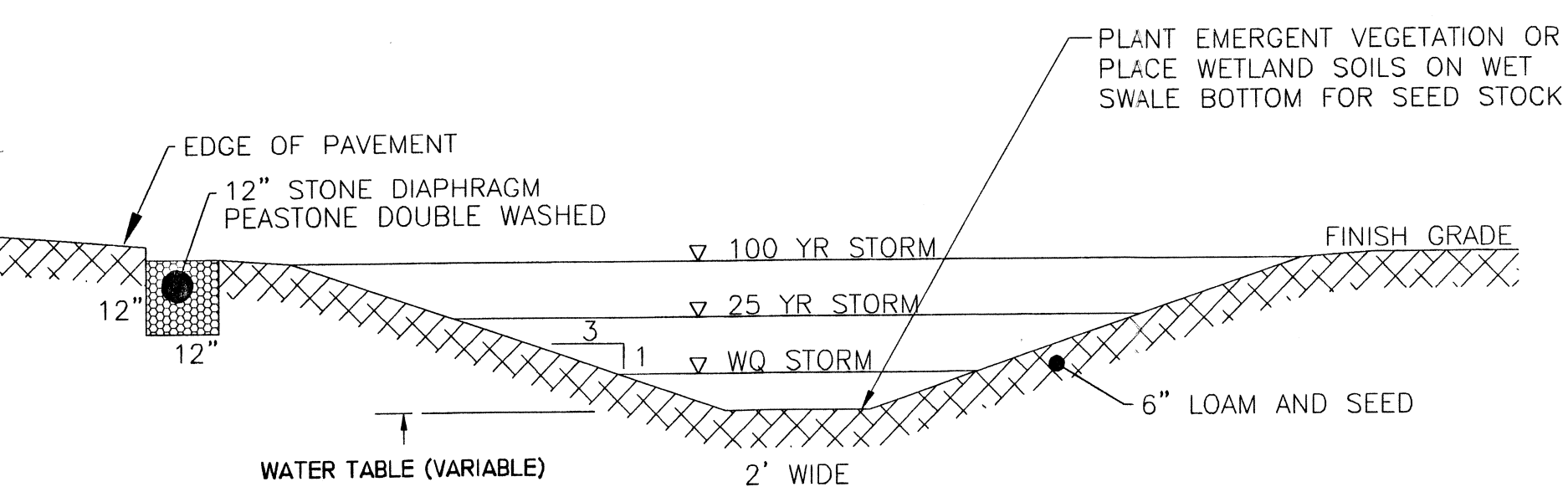

**WATER QUALITY SWALE**

(TYPICAL SECTION)  
NOT TO SCALE

- NOTES:**
1. MINIMUM LENGTH OF CHANNEL 100'
  2. SIDE SLOPES TO BE 3:1 OR FLATTER
  3. REFERENCE RIP RAP DETAIL FOR STONE SIZE AND BASE MATERIAL
  4. MINIMUM BOTTOM WIDTH 2' / MIN. DEPTH 1.0'

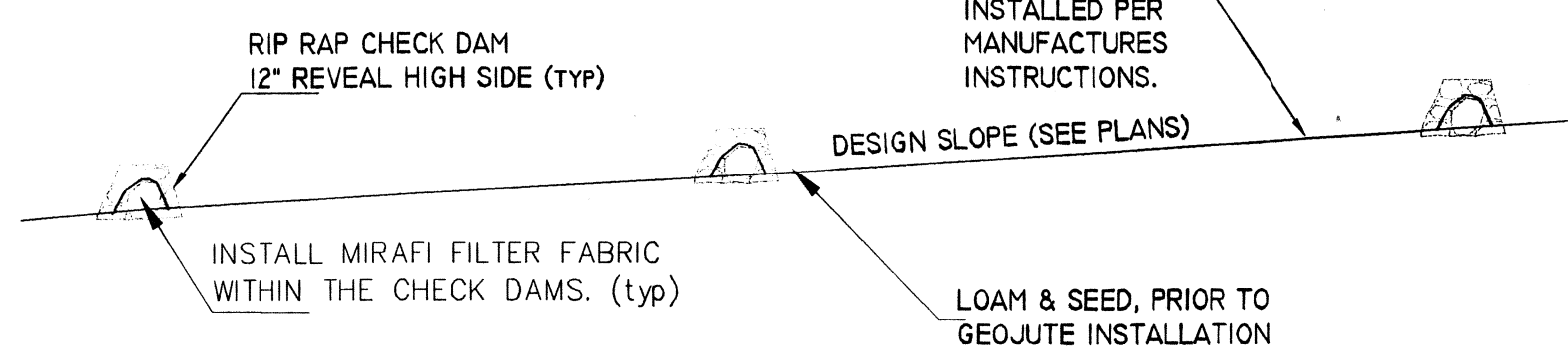

**WATER QUALITY SWALE - PROFILE**

NOT TO SCALE

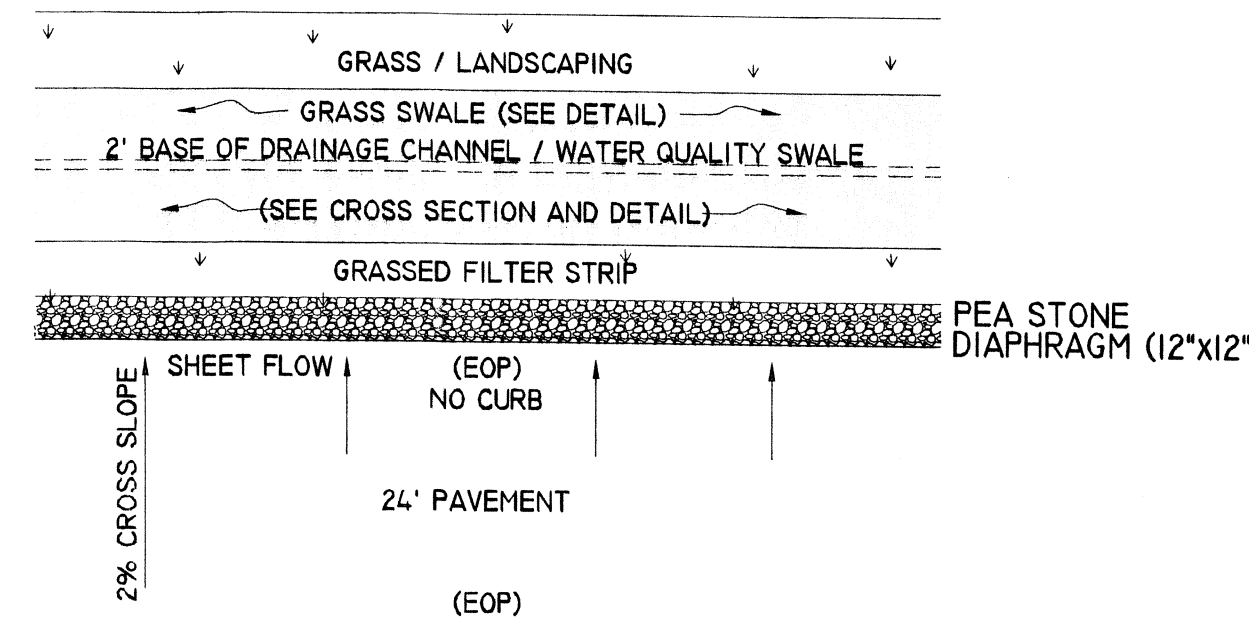

**PEA STONE DIAPHRAGM DETAIL**

(STA 1+50 TO 7+00, LEFT)  
NOT TO SCALE

**Seekonk Planning Board**

APPROVAL UNDER SUBDIVISION CONTROL LAW

\_\_\_\_\_  
 \_\_\_\_\_  
 \_\_\_\_\_  
 \_\_\_\_\_  
 CLERK \_\_\_\_\_ DATE \_\_\_\_\_

**DETAIL SHEET (2 OF 2)**

**"MADISON ESTATES"**

READ STREET SEEKONK, MASSACHUSETTS  
ASSESSORS MAP 24 LOT 66B

APPLICANT: COSTA DEVELOPMENT, LLC  
65 EMILY WAY, SEEKONK, MASSACHUSETTS 02771

JOB # 09-079	SCALE: AS-SHOWN	DRAWN BY: CEA	DATE: JUNE 21, 2010
REVISED: DECEMBER 1, 2010			

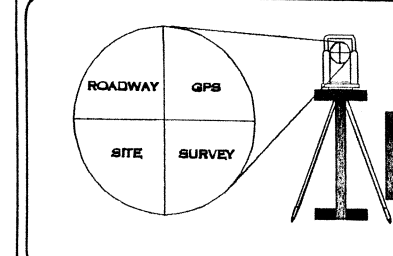
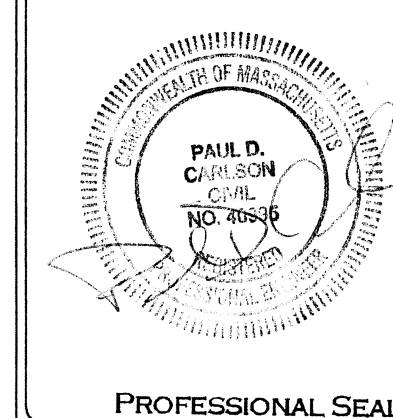

PROFESSIONAL ENGINEERS  
AND LAND SURVEYORS  
INSITE PROFESSIONAL COMPLEX, SUITE 1  
1539 FALL RIVER AVENUE  
SEEKONK, MA 02771  
PHONE: (508) 336-4500  
FAX: (508) 336-4558

SHEET  
**8**  
OF 9