



Conservation Commission
100 PECK STREET
SEEKONK, MASSACHUSETTS 02771
1 (508) 336-7400

RDA
17 Sanctuary
Lane

August 1, 2000

The Evening Times
23 Exchange Street
Pawtucket, RI 02862

Attention: LEGAL ADS - Karen Medeiros - Manager

Dear Ms. Medeiros:

Please print the enclosed legal ad in the Times edition of MONDAY, AUGUST 7, 2000.

Please send the bill and tear sheets to the Seekonk Conservation Commission, 100 Peck Street, Seekonk, MA

If you have any questions, please feel free to contact me at the Town Hall at 1-508-336-2961.

Sincerely,

Wahlene Siconio
Wahlene Siconio, Secretary
Conservation Commission

/ws



(Ad Copy)

**TOWN OF SEEKONK
CONSERVATION COMMISSION
PUBLIC MEETING**

The Conservation Commission in accordance with Mass. Gen. Law Ch. 131, §40 and the Seekonk Wetland Protection By Laws will hold a **PUBLIC MEETING** at the Seekonk Town Hall on **MONDAY, AUGUST 14, 2000** at **10:00 P.M.** on a Request to Determined filed by Wesley Grela, to install an above ground pool, and related grading, at 17 Sanctuary Lane, Seekonk, within buffer zone of BVW.

Plans are available for inspection at the Seekonk Town Hall during normal business hours.



NEW PROPOSED AREA FOR 15'x30' ABOVE GROUND SWIMMING POOL

ON 17-SANCTUARY LANE SEEKONK MA.

RDA
17 Sanctuary Lane

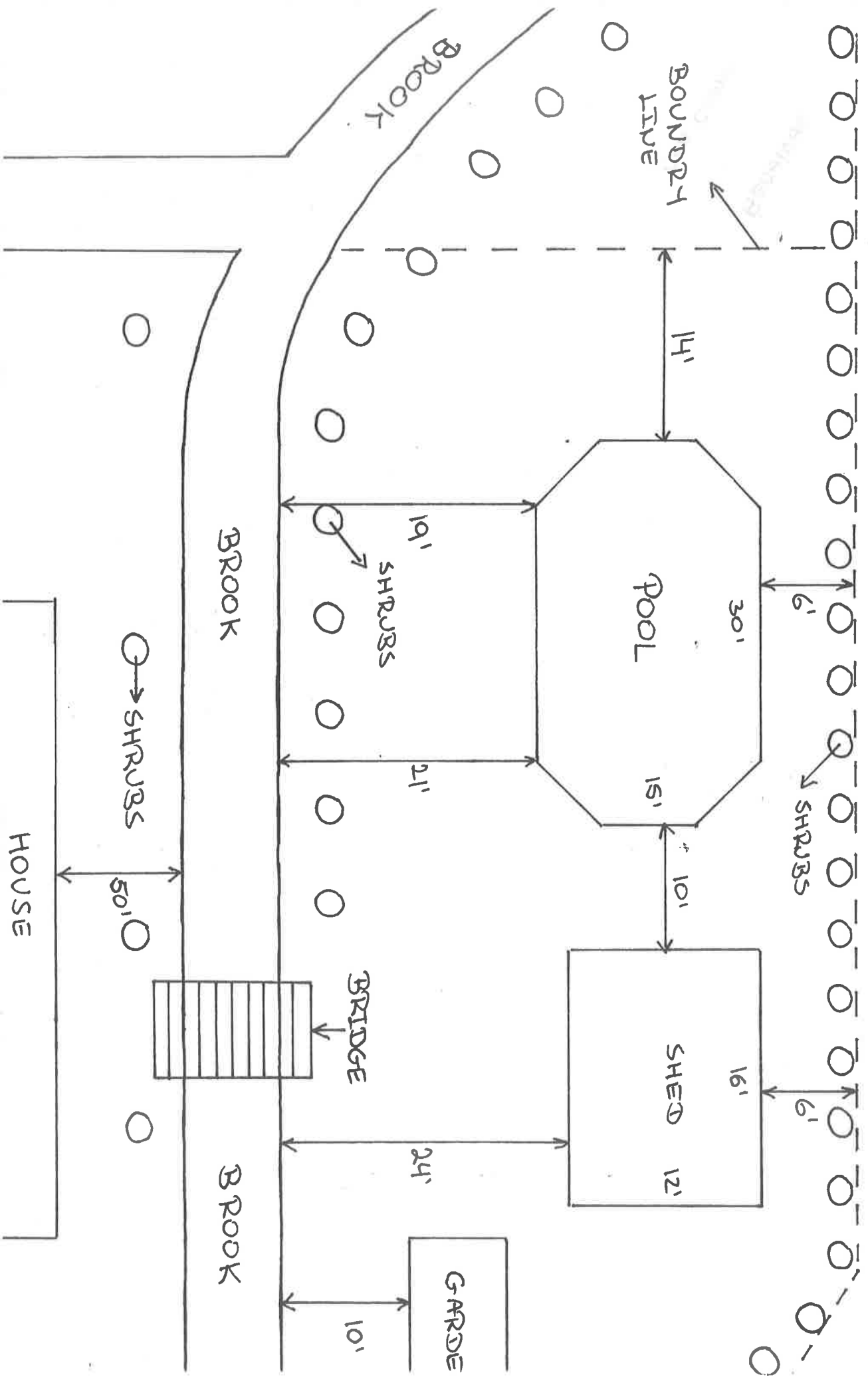

RDA
17 Sanctuary
Lane

File No: RTD 00-8

City/Town: Seekonk
Applicant: Grela

Request Filed 8/1/00

Form 2

Commonwealth
of Massachusetts

DETERMINATION OF APPLICABILITY

Massachusetts Wetlands Protection Act, G.L. c. 131, § 40

From Seekonk Conservation Commission Issuing Authority.

To Wesley Grela
(Name of person making request)

(Same)
(Name of property owner)

Address 17 Sanctuary Lane, Seekonk, MA

(Same)
(Address of property owner)

This determination is issued and delivered as follows:

by hand delivery to person making request on _____ (date)

by certified mail, return receipt requested on September 19, 2000 (date)

Pursuant to the authority of G.L. c. 131, §40, the Seekonk Conservation Commission has considered your request for a Determination of Applicability and its supporting documentation, and has made the following determination (check whichever is applicable):

Location: Street Address 17 Sanctuary Lane Plat Number: 29 Lot Number(s): 84

This Determination is positive.

1. The area described below, which includes all/part of the area described in your request, is an Area subject to Protection Under the Act. Therefore, any removing, filling, dredging or altering of that area requires the filing of a Notice of Intent.
2. The work described below, which includes all/part of the work described in your request, is within an Area Subject to Protection Under the Act and will remove, fill, dredge or alter that area. Therefore, said work requires the filing of a Notice of Intent.
3. The work described below, which includes all/part of the work described in your request, is within the Buffer Zone as defined in the regulations, and will alter an Area Subject to Protection Under the Act. Therefore, said work requires the filing of a Notice of Intent.

10.99 (continued)

This Determination is negative:

1. _____ The area described in your request is not an Area Subject to Protection Under the Act.
2. _____ The work described in your request is within an Area Subject to Protection Under the Act, but will not remove, fill, dredge, or alter that area. Therefore, said work does not require the filing of a Notice of Intent.
3. X _____ The work described in your request is within the Buffer Zone, as defined in the regulations, but will not permanently alter an Area Subject to Protection Under the Act. Therefore, said work does not require the filing of a Notice of Intent.
4. _____ The area described in your request is subject to Protection Under the Act, but since the work describe therein meets the requirements for the following exemption, as specified in the Act and the regulations, no Notice of Intent is required _____.

Issued by Seekonk Conservation Commission

Signature(s) Richard C. Waller R. F. Hill
Christopher Cleary
[Signature]

This Determination must be signed by a majority of the Conservation Commission.

On this 18th day of September 2000, before me personally appeared Richard Wallace, to me known to be the person described in, and who executed, the foregoing instrument, and acknowledged that he/she executed the same as his/her free act and deed.

Wablene J. Secorio
(Notary Public/Justice of the Peace)

June 25, 2004
(My Commission Expires)

This Determination does not relieve the applicant from complying with all other applicable federal, state or local statutes, ordinances, by-laws or regulations. This Determination shall be valid for three years from the date of issuance.

The applicant, the owner, any person aggrieved by this Determination, any owner of land abutting the land upon which the proposed work is to be done, or any ten residents of the city or town in which such land is located, are hereby notified of their right to request the Department of Environmental Protection to issue a Superseding Determination of Applicability, providing the request is made by certified mail or hand delivery to the Department, with the appropriate filing fee and Fee Transmittal Form as provided in 310 CMR 10.03(7) within ten days from the date of issuance of this Determination. A copy of the request shall at the same time be sent certified mail or hand delivery to the Conservation Commission and the applicant.