

Plan to Accompany
Amended
Notice of Intent in
BOXFORD, **MASS.**

Hayes Engineering, Inc.
Civil Engineers & Land Surveyors
603 Salem Street
Wakefield, MA 01880

Telephone: 781.246.2800
Facsimile: 781.246.7596
www.hayeseng.com

Hayes

Scale: 1" = 20'



October 29, 2015

SHOWING PROPOSED EXPANSION OF EXISTING DECK

OWNER
DAVID AND MARY KATHERINE KREIDER
46 IPSWICH ROAD
BOXFORD, MASS. 01921
MAP 26 BLOCK 02 LOT 13

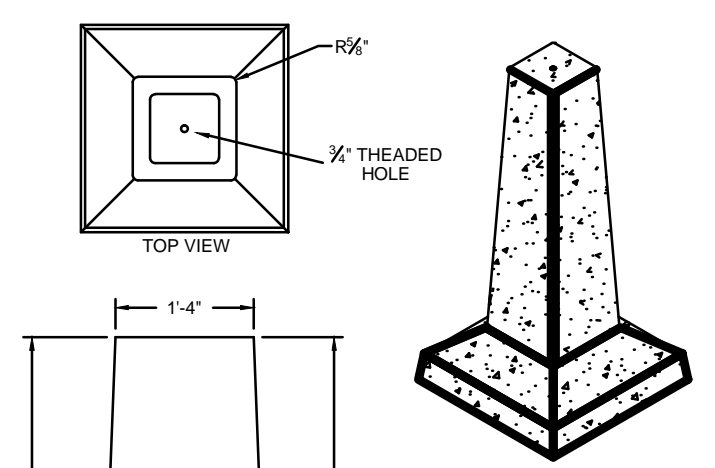

PRECAST FOOTING/FROST POST:
LOAD BEARING AT TOP =
CONCRETE PSI * AREA * FACTOR OF SAFETY
4000PSI * (16'16") * 0.45 = 460,800LBS

LOAD BEARING AT SOIL =
SOIL PRESSURE * AREA =
2000PSF * (2'2") * 12,500LBS

THEREFORE MAX LOAD BEARING IS LIMITED
TO SOIL CONDITIONS OF 12,500LBS

ITEM	WEIGHT
SONATUBE	1200#

FOOTING/FROST POST
SONATUBE 16" SQUARE
MF2

SONATUBE16SQ.dwg 3/2/2010

LEGEND OF SYMBOLS & ABBREVIATIONS:

x 100.0	EXIST. SPOT ELEVATION	◻	TEST HOLE
100	EXIST. CONTOUR	◼	PERC TEST
100.0	PROP. SPOT ELEVATIONS	⊙	DRAIN MANHOLE
100	PROP. CONTOURS	▣	CATCH BASIN
---	PROP. WATER SUPPLY LINE	⊕	WATER SUPPLY WELL
○ MW	PROP. INSPECTION PORT/MONITORING WELL		

BENCHMARK REFERENCE DATUM: ASSUMED
GARAGE FLOOR. ELEV.=100.00'